

Dynamic Behavior of a Distribution System: High Penetration Level of Micro-turbines

F. Gonzalez-Longatt, *Member IEEE*, C. Peraza, and C. Villanueva, *Member, IEEE*

Abstract—Utility restructuring, technology evolution, public environmental policy, and expanding power demand are providing the opportunity for micro-turbines to become important energy resources. In order to investigate the ability of micro-turbine units in distribution systems, new simulation tools are needed. This paper presents a dynamic model for micro-turbines. The novelty of this paper is the use of the controls-oriented model of a permanent magnet synchronous generator. Furthermore, a realistic voltage source inverter with current band hysteresis control is included to simulate the micro-turbine system. The micro-turbine model is implemented in simulation software, and proved in grid-connected mode for several loading sequences. The impact of high penetration levels of micro-turbines plants in a typical distribution feeder is discussed too.

Index Terms—Distribution system, dynamic behavior, micro-turbine, modeling, simulation

I. INTRODUCTION

POWER industry has nearly completely changed its traditional structure. The electric market growth, the financial market's development and the accelerated technical progress have made the optimum size in new investments in generation to decrease, in relation to the market's size and to the private financial capacity [1]. Additionally, the deregulation processes that have been appearing in the whole world have made this possible by promoting competence in generation. All this, opened the opportunities for on-site power generation by electricity users using smaller generating system with emergent technologies. The distributed generation (DG) - small power generators typically located at users' sites where the energy (both electric and thermal) they generate is used - have emerged as a promising option to meet growing customer needs for electric power with an emphasis on reliability and power quality [2]. Distributed energy resources include a variety of energy sources, such as photovoltaic, fuel cells, storage devices and micro turbines, with capacities in the 1 kW to 10MW range [3].

Manuscript received August 22, 2005.

F. G. L. is with Department of Electrical Engineering, Universidad Nacional Experimental Politécnica de la Fuerza Armada Nacional, Maracay, 2122 Venezuela (phone: +58-414-4572832; fax: +58-243-5546954; e-mail: fglongatt@ieee.org).

C. P. is with Instituto Universitario de Tecnología Valencia, 2022 Venezuela (phone: +58-241-868-7812; e-mail: cperazam@cantv.net).

C. V. is with the Electrical Engineering Department, Universidad de Carabobo, Valencia, 2022 (phone: +58-412-8893302, e-mail: cvillanu@uc.edu.ve).

The fundamental concepts for the penetration of DG technologies are the high efficiency of the energy conversion process and the limited emission of pollutants with respect to conventional power plants [4].

Major improvements in the economic, operational, and environmental performance of small, modular units have been achieved through decades of intensive research. Among such DG, micro-turbines and fuel cells show particular promise as they can operate on multiple fuels with low emissions, high efficiency and high reliability [5]. Micro-turbines are small and simple-cycle gas turbines with outputs ranging from around 25 to 300 kW. They are one part of a general evolution in gas turbine technology. Techniques incorporated into the larger machines to improve performance can be typically found in micro-turbines as well. These include recuperation, low NO_x technologies, and the potential use of advanced materials such as ceramics for hot section parts [5], [6], [7].

DG offer a higher flexibility and load management, the integration of modular generating units in the power system may provide a number of significant local benefits regarding both peak demand coverage and the possibility of delaying the adjustment of the transmission and distribution network [4]. In other hand, Distribution networks are losing their feature of purely passive networks and will be near to demand a service of dispatching for the involved plants thus requiring a different approach to operate, specially the dynamic behavior.

As micro-turbines will likely become major DGs in the near future, it is necessary to deal with dynamic models of micro-turbine. This paper describes the development of a dynamic model of a micro-turbine system and this is used to simulate the dynamic behavior of a distribution network with high penetration level of micro-turbines. The organization of this paper is as follows. The micro-turbine model is given in the next section, followed. A test distribution system with a micro-turbine plant is developed. And finally results are presented and commented, and conclusions are presented.

II. MICRO-TURBINE MODELING

There are essentially two types of micro-turbines. One is a high-speed single-shaft unit with the compressor and turbine mounted on the same shaft as the electrical alternator. Turbine speeds mainly range from 50 000 to 120 000 rpm. The other type of micro-turbines is a split-shaft design that uses a power turbine rotating at 3600 rpm and a conventional generator (usually induction generator) connected via a gearbox. The

designs are composed of the following four or five parts:

1) *Turbine*. There are two kinds of turbines, high-speed single-shaft turbines and split-shaft turbines. All are small gas turbines.

2) *Alternator or conventional machine*. In the single-shaft design, an alternator is directly coupled to the single-shaft turbine. The rotor is either a two- or four-pole permanent magnet design, and the stator is a conventional copper wound design. In the split-shaft design, a conventional induction or synchronous machine is mounted on the power turbine via a gearbox.

3) *Power electronics*. In the single-shaft design, the alternator generates a very high frequency three phase signal ranging from 1500 to 4000 Hz. The high frequency voltage is first rectified and then inverted to a normal 50 or 60 Hz voltage. In the split-shaft turbine design, power inverters are not needed.

4) *Recuperator*. The recuperator is a heat exchanger, which transfers heat from the exhaust gas to the discharge air before it enters the combustor. This reduces the amount of fuel required to raise the discharge air temperature to that required by the turbine.

5) *Control and communication systems*. Control and communication systems include full control of the turbine, power inverter and start-up electronics as well as instrumentation, signal conditioning, data logging, diagnostics, and user control communication.

Here, we are mainly interested in the slow dynamic performance of high-speed single-shaft turbines. A block diagram of a single shaft micro-turbine system is shown in Figure. 1.

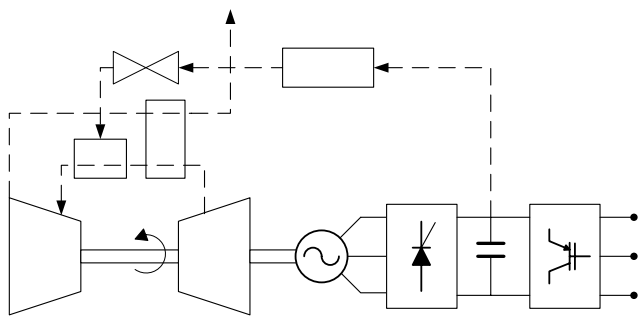

Fig. 1. Micro-turbine generation system.

A. Mechanical Considerations

The micro-turbine's electric-mechanical behavior is our main interest. The recuperator is not included in the model as it is only a heat exchanger to raise engine efficiency. Also, due to the recuperator's very slow response time, it has little influence on the time-scale of our dynamic simulations.

The gas turbine's temperature control and acceleration control are of no significance under normal system conditions. They can be omitted in the turbine model. From a modeling standpoint, this analysis will view the mechanical system,

including the turbine, as a lumped moment of inertia, *J*. The mechanical system will control the torque applied to the generator.

B. Electrical Considerations

The micro-turbines are very small gas combustion turbines, featuring a single shaft structure with no gearboxes and rotating at very high speed, typically between 50,000 and 120,000 rpm/min; as a consequence these machines are always equipped with permanent magnet synchronous generators (PMSG) to produce electricity.

The generator is a PMSG type, which feeds a rectifier. The rectifier supports a dc link, which is the input to the voltage source inverter. The rectifier and dc link may be one of several possible configurations, could be an active one, or there could be a chopper used to regulate the bus voltage. The inverter is a voltage source inverter that could be pulse width modulation (PWM), space vector, or any other choice [8].

The micro-turbine operates as mechanical power source with variable speed, coupling to a PMSG, the ac output of the PMSG is converted in a dc link witch in turn supplies power to a load. This displayed on the Figure 2. In this case, a passive rectifier is considered, and the load is another converter, a voltage source inverter (VSI) with hysteresis current control.

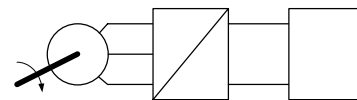

Fig. 2. Block diagram of micro-turbine generator to load.

1) PMSG

The PMSG for micro-turbine is of the designed with high number of poles and small amount of saliency, can be modeled by voltage behind a reactance [8], [9]. The ac-dc interface between PMSG and dc link is a simple, full-wave, diode bridge rectifier (FWDB), coupled directly to a dc bus capacitor. This is depicted in Figure 3, where phase resistance has been assumed negligible.

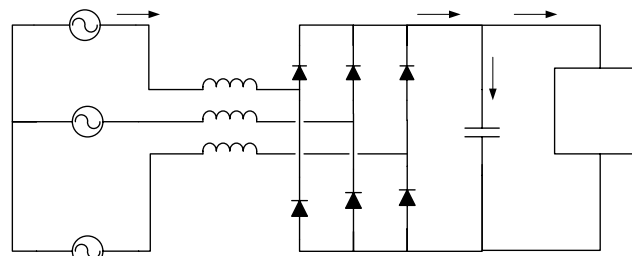

Fig. 3. FW Rectification into a stiff dc bus.

A PMSG with FWBD, can be modeled by a nearly liner regulation curve [8]:

$$V_{dc} = K_e \omega_m - K_x \omega_m I_{dc} [V] \tag{1}$$

where the constants are defined as,

$$K_e = \frac{3pK_V}{2\pi} \left[\frac{V}{rad / seg} \right] \tag{2}$$

TABLE I
PARAMETER OF THE PMSG MODEL

Parameter	Value	Unit
Rated Speed	60,000	rpm
Number of poles	2	-
Rated Power	75	kW
Inertia Constant	0.085	kg-m ²
K_e	0.092	V/(rad/s)
K_v	0.096	V/(rad/s)
K_s	8.459×10^{-5}	Ω /(rad/seg)

A. Grid-Connected Mode

The micro-turbine was connected to the utility grid and operated in grid-connect mode. To evaluate the dynamic behavior of the micro-turbine several simulations were developed considering load changes.

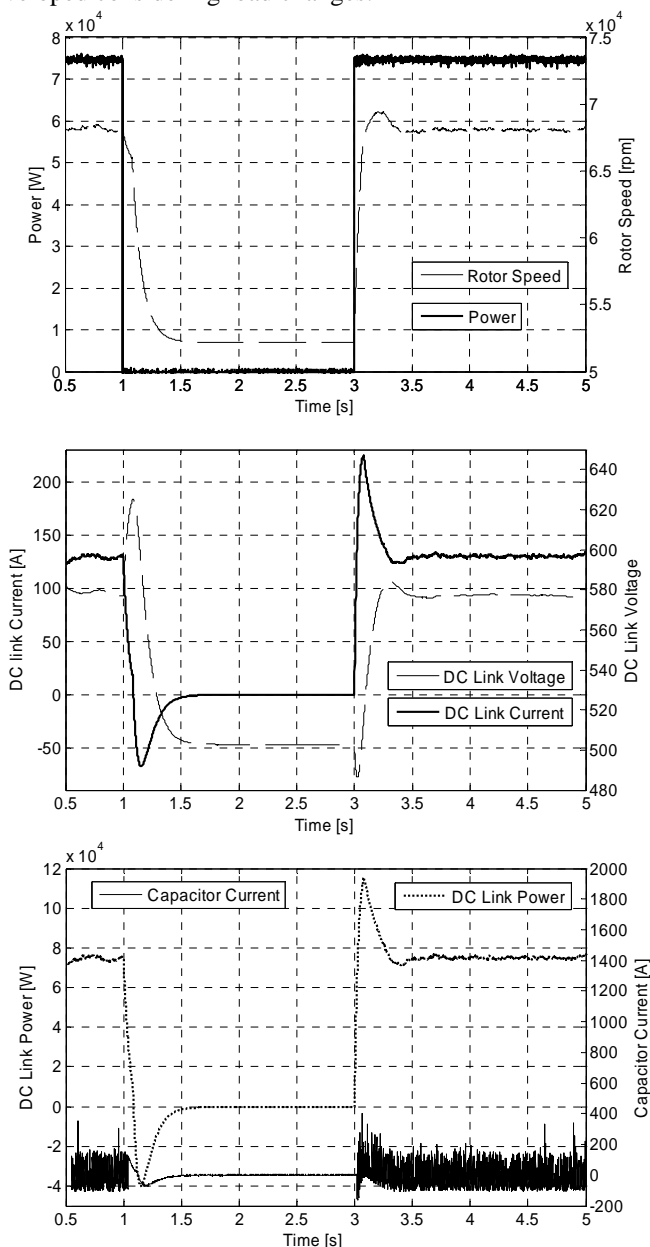

Fig. 7. Power output, rotor speed DC link voltage and current, dc power and capacitor current for full-no-full load cycle.

A complete load cycle was simulated, starting at rated output, stepped down to no-load and then stepped to rated output; results are shown in Fig. 7.

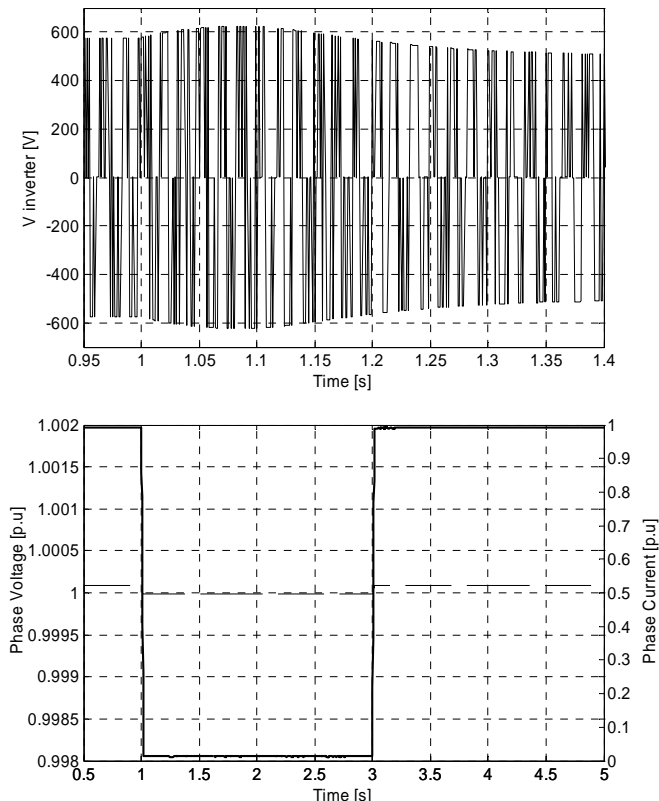

Fig. 8. Inverter voltage, phase voltage and current in per unit.

During a step down in micro-turbine power output, several characteristics could be seen. First when the power reduction command was entered, there was an immediate rise in the DC link voltage (15 to 20 volts), followed shortly by a rise in the turbine shaft speed (1,000 to 1,500 rpm). As the micro-turbine reached the new power level, turbine speed stabilized at a lower level (52,000 rpm). The dc link voltage reduced to about 500 volts and went no lower. During a step up in the micro-turbine power output, a similar set of circumstances prevailed. When the output increase command was entered, the turbine shaft speed and dc link voltage both increased quickly and peaked when power reached the new setting. Dc link voltages increased from 30 to 50 Vdc as turbine speed increased from 3,000 to 13,000 RPM. When the new operating level was established, the turbine speed and DC link voltage levels decreased to steady-state levels for that power output.

Interesting transient is shown on the capacitor current. During the step down in micro-turbine power output, the capacitor is charged with a current transient about 0.5 sec, and during step up of output power, the capacitor is discharged rapidly.

The inverter voltage can be seen on Fig 8, and terminals variable exhibit a perfect dynamic behavior. The voltage regulation looks good as seen on Fig 8. From no-load to full load, the regulation is below 0.5%.

Two loading sequences were simulated. Load step changes

for 20 percent of the rated power, was considered. Only active power step was simulated, the micro-turbine was assumed operating at unity power factor. After each step change, a short period of time was allowed for variable stabilization before next step change was initialized. Step changes for 20 percent of the rated power. The first is power steps of 15 kW starting from 75 kW, stepping to 0 kW and then stepping back to 75 kW (Fig. 9)

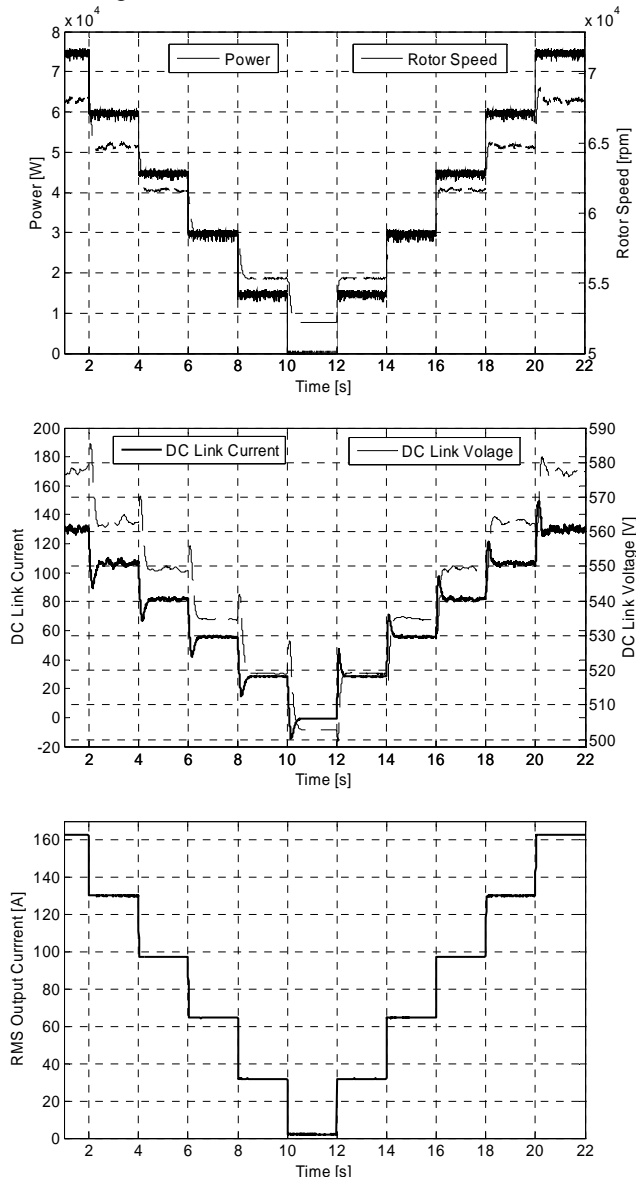

Fig. 9. Power, rotor speed, dc link current and voltage, phase current for first loading sequence.

The second loading sequence contains power steps of 15 kW starting from no load, stepping to rated power and then stepping back to no load (Fig. 10).

Based on the simulation of both loading sequences, we highlight that the transition times during power increase and decrease were similar. Note the speed overshoot in both the positive and negative load change directions. Furthermore, the simulation demonstrate the fast dynamic behavior of the micro turbine, and show that this device can respond to load changes rapidly.

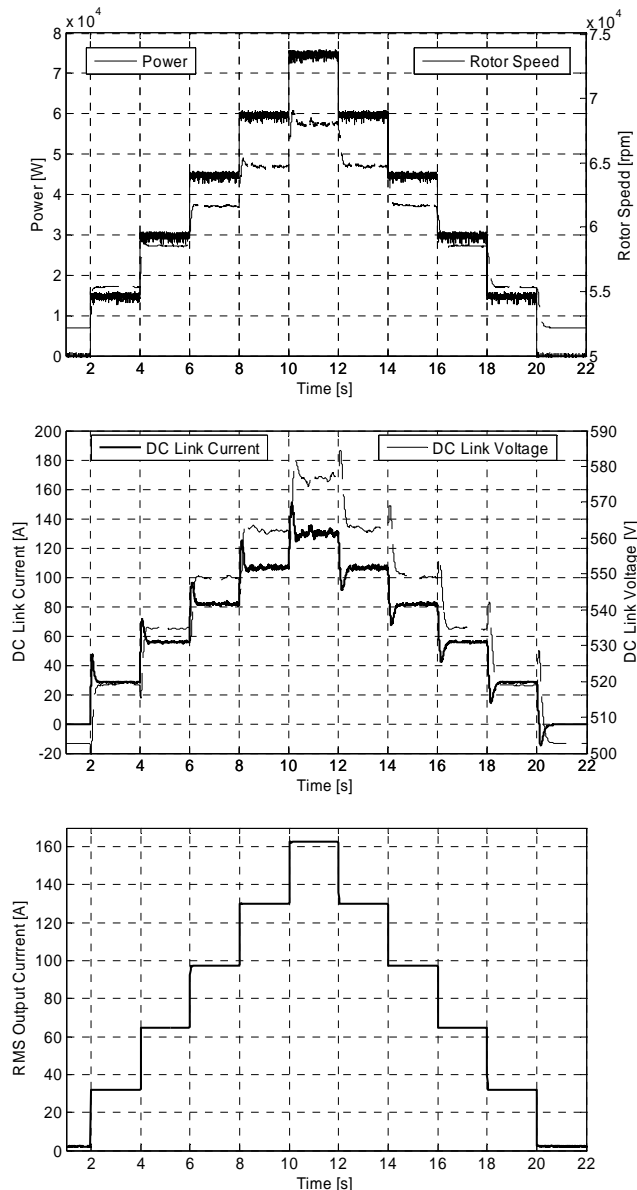

Fig. 10. Power, rotor speed, dc link current and voltage, phase current for second loading sequence.

To evaluate the impact of the high penetration level of micro-turbines based resources, a typical five buses distribution feeder as shown in Fig. 11, with radial topology was simulated.

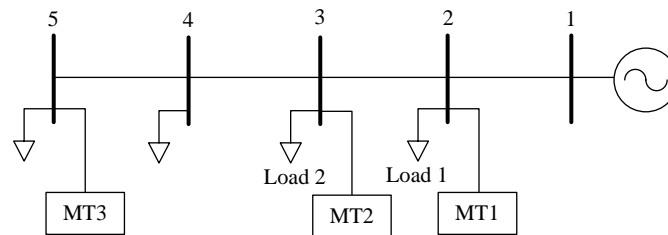

Fig. 11. Distribution System Diagram.

For simplicity, only real power is consumed by the load, and they are modelled by impedance constant. Three micro turbine plants are included, MT1, MT2 and MT3 at buses 2, 3 and 5 respectively. Each plants consist a single-shaft micro-turbine with $P_{rate} = 75kW$ and $V_{rate} = 480 Vac$ as modelled

above. A step up transformer was include for connect each micro-turbine to the 6,600 volts level of the distribution feeder. The network and units parameters are not due to space limits. Thought the power conditioner of the fuel cell system can output not only real power, for simplicity only real power output is considered to the inverter. The inverter control system is designed to follow the load at the terminal of the micro turbine.

Suppose at a certain time, the total load in this distribution system is $P_{load} = 100$ kW, and each micro-turbine is adjusted to fed all the power of the local load at the bus. The micro turbine penetration level is about 75%. A sequential step increase of 100 % on Load 2, 3 and 5 occurs in time: 0.5s, 0.6s, and 0.7s. Fig. 12 shows the dynamic response of rotor speed, and dc link variables.

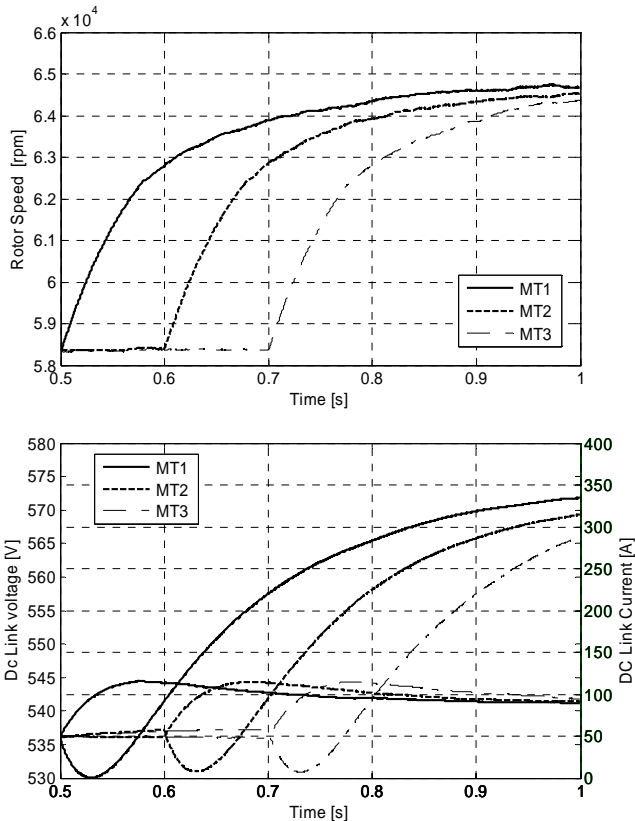

Fig. 12. Rotor speed, dc link voltage and current for micro turbine 1,2 y 3, 100% load step

Changes of the rotor speed for three micro turbines is similar, because this machines are coherent. When the micro turbine output increase, the turbine shaft speed and dc link voltage both increased quickly and peaked when power reached the new setting. Dc link voltages increased from 10 to 20 Vdc as turbine speed increased 5,000 to 8,000 rpm. Finally, a sequential step increase of 400 % on Load 2, 3 and 5 occurs in time: 0.5s, 0.6s, and 0.7s was simulated. Fig. 13 shows the dynamic response of inter-tie power flow and the output power of each micro-turbine. Furthermore dc link variables behaviour is shown in Fig. 13. The load increase force the micro turbine output to reach the rate power, then the control system acts to prevent the overload of the plant.

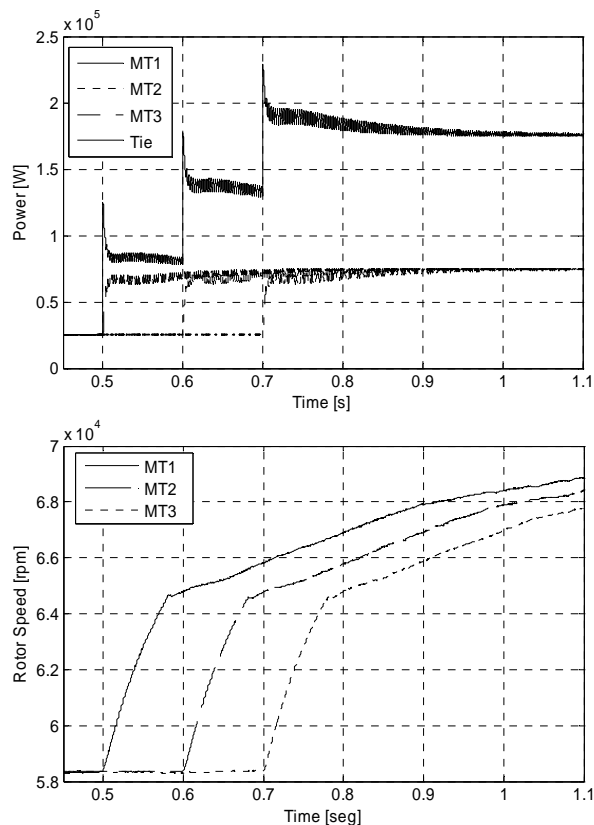

Fig. 13. Inter-tie power flow, power output and rotor speed for micro-turbine 1,2 and 3, 400% load step

The power difference between that developed by the micro-turbine and that required by the load is supplied by the grid as shown on Fig 13. The rotors speed exhibit a saturation characteristic motivated for the speed limitation and power limitation control system.

IV. CONCLUSION

In this paper a simple model of a single-shaft micro turbine system suitable for dynamic behavior studies was developed. The novelty of this paper is the use of the controls-oriented model of a permanent magnet synchronous generator, to modeling the PMSG output after the full-wave diode rectifier into a voltage-stiff DC bus. Furthermore, a realistic voltage source inverter with current band hysteresis control was include to simulate the micro-turbine system.

This model results suitable for dynamic behavior studies as demonstrated in this paper with several simulations.

Simulations of several loading sequences shows similar transition times during power increase and decrease. And speed overshoot in was found both the positive and negative load change directions. The fast dynamic behavior of the micro turbine was demonstrated, and the feasibility of this device to respond to load changes rapidly.

REFERENCES

- [1] Hunt, Sally and Shuttleworth, Graham. Competition and Choice in Electricity. John Wiley & Sons, England (1996).
- [2] C. Peraza, F. González-Longatt and C. Villanueva. "Dynamic Performance Implications of the Power Conditioner Grid-Connected for

- Photovoltaic Source". (Published Conference Proceedings style)," in *Proc. ICREPQ'05*, Zaragoza, Spain, 1994, pp. 217-221.
- [3] R. H. Lasseter. "Control of Distributed Resources". Bulk Power System Dynamics and Control IV - Restructuring, August 24-28, Santorini, Greece.
- [4] A. Bertani, C. Bossi, F. Fornari, S. Massucco et al. "A microturbine generation system for grid connected and islanding operation". *Power Systems Conference and Exposition, 2004. IEEE PES* 10-13 Oct. 2004. pp. 360-365 vol.1.
- [5] Y. Zhu and K. Tomsovic, "Development of Models for Analyzing the Load Following Performance of Microturbines and Fuel Cells," *Journal of Electric Power Systems Research*, Vol. 62, Issue 1, May 2002, pp. 1-11
- [6] J.H. Watts, Microturbines: a new class of gas turbine engines, *Gas Turbine News in Brief* 39 (1) (1999) 5 _ 11, [Online]. Available <http://www.asme.org/igti/ggtn/archives.html>.
- [7] Y. Zhu. "Analysis and Control of Distributed Energy Resources "(Thesis or Dissertation style)," Ph.D. dissertation, Dept. Elect. Eng., Washington State Univ., Washington, MA, 2002.
- [8] M.J. Ryan, R.D. Lorenz. "A Novel Controls-Oriented Model of a PM Generator with Diode Bridge Output," *WEMPEC Research Report*, pp. 97-106.
- [9] A.R. Bergen. *Power System Analysis*. Prentice-Hall, Englewood Cliffs, New Jersey, 1989.
- [10] M.C. Chandorkar, D.M. Divan, and R. Adapa, "Control of parallel connected inverters in stand-alone ac supply systems." *IEEE Trans. on Industry Applications*, January/February 1993. pp. 136-143.
- [11] L. Angquist and L. Lindbrg, "Inner phase angle control of voltage source inverter in high power application", *IEEE PESC Conf. Rec.* 1991. pp. 293-298.